

Cornwell Incorporated

REAL ESTATE AUCTION

For Fred Richter Estate

April 30, 2024 | 6:30pm CST

LIVE AUCTION on the property
505 N 2nd Ave. Shelby, NE 68662
OPEN HOUSE TO VIEW THE HOME

April 28, 2024 1:00-3:00pm & April 30, 2024 prior to auction

3 Bedroom – 2 Bathrooms – Living, dining, kitchen, laundry room – All appliances included –
 1,304 sq ft mobile home on concrete foundation with crawlspace – Located on a large lot –
 Detached garage & carport

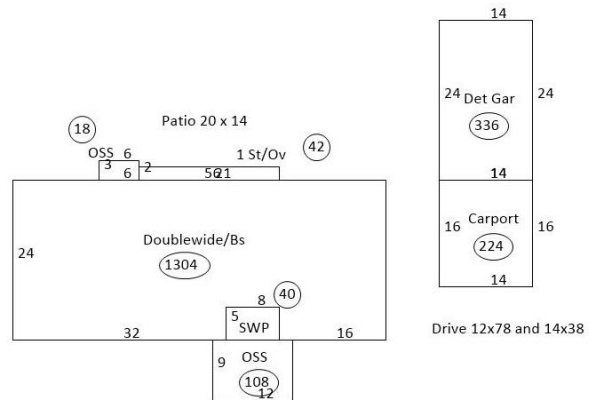

Home is selling as-is, where-is, with no guarantees. Buyer's inspections are encouraged prior to the house selling, house will be open for inspection on April 28, 2024 from 1:00pm-3:00pm and April 30, 2024 prior to the auction. All financing arrangements must be lined up prior to the auction. Sale is NOT contingent upon financing. Pre-Approval letter will be required to receive a bidder number. 2023 taxes \$521.

TERMS OF SALE; 10% Down payment day of Sale; Balance due on or Before May 31, 2024 at which time a marketable title will be delivered. Cornwell Inc. are agents of the seller.

For a private showing or additional information, contact
Clint Mickey, Broker, 402-694-8470 | www.cornwellauction.com

